

**8539**  
120V

Catalog #:		Type
Project:		Date
Prepared by:		

## 7" High-lumen Slim Round Disk

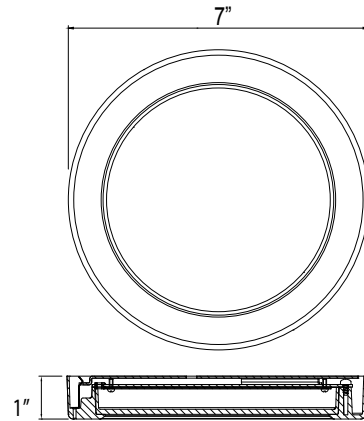

### DESCRIPTION

The high-lumen Slim Round LED Disk Light that is an affordable, attractive and versatile solution for an LED down light. Suitable for use in wet locations, this is a great choice for most any residential or light-commercial application.

### DESIGN FEATURES

#### Construction

- 1" Slim profile - 8539 light fixture
- Durable steel frame
- Frosted acrylic lens to reduce glare and provide even light distribution

#### Electrical

- 120V-60Hz
- Dimmable TRIAC, 10-100%
- 50,000 hour projected life
- 14W | 1050lm
- 3000K | 80 CRI

#### Installation

- Mounting bracket included for installation in 3" or 4" J-Box applications
- Retrofit option available for installation in recessed housing with tension springs

#### EM Battery Pack (sold separately)

- Available in White (WH) only
- Empty Filler Housing also available
- See page 2 for further information

#### Certifications

- 8539: Energy Star Listed
- 8539: cCSAus Listed for wet location
- LED: 5 Year Limited Warranty
- Non-Electrical: 1 Year Limited Warranty
- Suitable for use in closets when installed in accordance to NEC Section 410.16 (C)(1)

*Example: 8539WH-80-3K*

Model #	Finish	CRI	CCT	Retrofit Option
8539		-80		
8539	BN : Brushed Nickel OB : Oil Rubbed Bronze BK : Black WH : White	-80	-3K : 3000K	-R : for recessed Housing Installation

#### ORDERING GUIDE

Model #	
4785EM	: EM Batter Backup with Test Switch
4785F	: Empty Filler Housing Only

TEL: 800.937.6925 | Fax: 800.207.9509 | [www.rplighting.com](http://www.rplighting.com)

Specifications and dimensions subject to change without notice.

12/28/2020 R1



RP LIGHTING • FANS

7" High-lumen Slim Round Disk

# 4785EM

120V-60Hz

## 7" LED Flush Mount Emergency Back-up

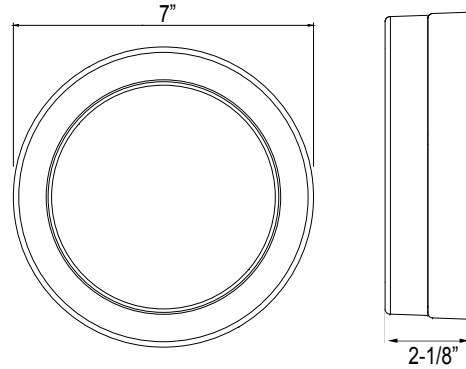

Emergency Back-Up/Empty Filler Unit,  
including 8536 or 8539 disk

### DESCRIPTION

For use with the RP Lighting's 8536/8539 disk, this maintenance-free emergency back-up unit with rechargeable Ni-MH battery allows for emergency power down corridors or open applications. With the blank empty filler unit you can now have a similar appearance in the space when using the emergency unit.

### DESIGN FEATURES

#### Construction

- Durable metallic structure and heat sink to facilitate heat dissipation

#### Electrical

- 120V - 60Hz
- Non-Switch Loads Only (Always On Applications)
- Battery - 11.1V / 2.6Ah Ni-MH Re-chargable; up to 24 hours charge time
- Emergency Output - 600 nominal lumens
- Provides over 120 minutes when normal power fails
- LED Indications - Red - Charging; Green - Fully Charged; Yellow - Faulty
- Operating Temperature - 0°C (32°F) to +55°C (+131°F)
- Test Switch / Charging Indicator Light: 4W-ITS (4-wire illuminated test switch)

#### Installation

- For use with 8536 or 8539 disks from RP Lighting
- One-piece emergency back-up unit allowing for 3" or 4" J-Box installation

#### Certifications

- 4785EM/4785F: CSAus Listed for damp location
- Battery: 5 Year Limited Warranty
- Non Electrical: 1 Year Limited Warranty

#### J-Box Mounting

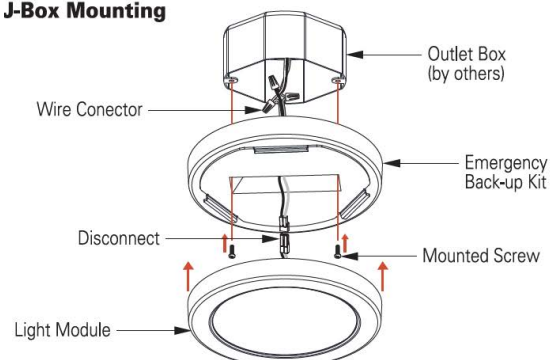

TEL: 800.937.6925 | Fax: 800.207.9509 | [www.rplighting.com](http://www.rplighting.com)

Specifications and dimensions subject to change without notice.

12/28/2020 R1



Battery Non-electrical

RP LIGHTING • FANS