

**8771**  
120V

Catalog #:		Type
Project:		Date
Prepared by:		

## 4" Recessed LED Gimbal Module

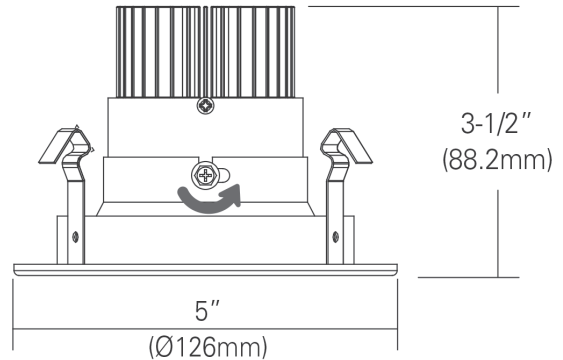

4" Recessed LED Module

### DESCRIPTION

The 8771 is a 4" Recessed LED Gimbal Module that is a quick, easy, and affordable way to upgrade to an energy efficient LED down light solution. Flexible for use in both retrofit and new construction applications, and suitable for use in damp locations, this is a ideal choice for most any residential or light-commercial environment.

### DESIGN FEATURES

#### Construction

- Spun aluminum housing provides ample heatsinking

#### Electrical

- 120V-60Hz
- Triac dimmable
- Suitable for use in damp locations
- 30,000 hour projected life
- 80CRI: 10W | 895Lm | 89.5Lm/W | Power Factor 0.99
- 90CRI: 10W | 717Lm | 71.7Lm/W | Power Factor 0.99
- Available in 2700\*, 3000 or 4000K | 82 or 92CRI

#### Installation

- Simple and easy 4" recessed housing installation
- E26 adapter is standard

#### Finish

- Available in White Finish
- \*Oil Rubbed Bronze (OB) and Brushed Nickel (BN) Special Order

#### Certifications

- Energy Star
- cCSAus Certified
- 5 year limited warranty

### ORDERING

Example: 8771WH-90-3K

Model #	Finish	CRI	CCT
8771			
8771	WH : White	-82	-27*
	*BN : Brushed Nickel	-92	-3K
	*OB : Oil Rubbed Bronze		-4K

\*2700 Special Order

\*Oil Rubbed Bronze (OB) and Brushed Nickel (BN) Special Order



TEL: 800.937.6925 | Fax: 800.207.9509 | [www.rplighting.com](http://www.rplighting.com)

Specifications and dimensions subject to change without notice.

