

# 4507

120V/277V

Catalog #:		Type
Project:		Date
Prepared by:		

## LED Wall Mount Sconce



-2S Circle



-3S Half Moon



-4S Stripe



-5S New Moon

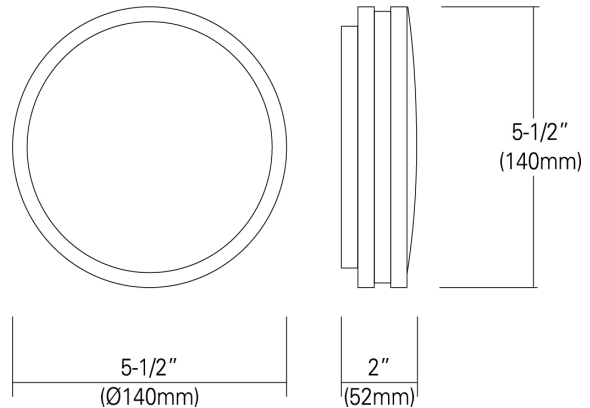

LED Wall Mount Sconce

### DESCRIPTION

These sleek LED Wall Mount Sconces are an energy efficient LED light that comes complete with an integrated LED light engine.

### DESIGN FEATURES

#### Construction

- Stainless Steel faceplate over an acrylic diffuser
- Select from various faceplate designs
- Suitable for indoor and outdoor use

#### Electrical

- 120V/277V
- Triac Dimmable at 120V
- 50,000 hour projected life
- 90 CRI
- Available in 2700K, 3000K, 4000K and 5000K
- 10W, 600lm, 60lm/W

#### Finish

- Available in brushed nickel (BN)

#### Certifications

- cCSAus certified for wet location
- State of California Title 24
- 5 years limited warranty

#### MOQ

- Minimum Order Quantity: 200



TEL: 800.937.6925 | Fax: 800.207.9509 | [www.rplighting.com](http://www.rplighting.com)

Specifications and dimensions subject to change without notice.



SPECIAL ORDER

# 4507

120V/277V

## Specification & Ordering

### ORDERING

Example: 4507-2S-27-90-BN

Model #	Faceplate	CCT	CRI	Finish
			-90	-BN
4507 10W	-2S : Circle -3S : Half moon -4S : Stripe -5S : New moon	-27K : 2700K -3K : 3000K -4K : 4000K -5K : 5000K	-90 : 90	-BN : Brushed Nickel

LED Wall Mount Sconce

SPECIAL ORDER

