



# SPECIFICATION

Product Name: High installation sensor

Model No.: MC083V RC

Issue Date: 13th 8, 2019

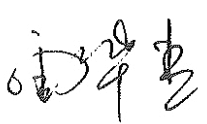
CUSTOMER APPROVED

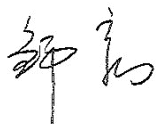
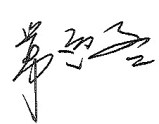
PRODUCT DIRECTOR APPROVED	SALES CHECKED	R&D CHECKED	PREPARED
			

## 1. Features



- High installation, can support 12m mounting
- 1-10V dimming interface, two-step / three-step dimming function with 1-10V drive.
- Infrared remote control design, users can configure each sense parameter according to needs.
- Support high-sensitivity and low-sensitivity mode (for metal ceiling, metal reflective surface installation environment)
- New patented remote control to adjust the launch angle to avoid mis-operation
- Override function

## 2. Parameter

<b>Input</b>	Operating Voltage	108-305V AC 50/60Hz
	DC Input Voltage	N/A
	Rated Voltage	120/277V AC 50/60Hz
	No-load Power	N/A
	Stand-by Power	≤1W
	Surge Test	L--N: 1kV
<b>Output</b>	Working Mode	ON/OFF function, 1-10V step dimming
	Type of Load	Inductive or resistive Load
	Load Capacity	2A @120Vac ,3A@277Vac, 3A@220-240Vac
	Current of Load	N/A
	Max. Surge Capacity	30A (50%Ipeak,twidth =500uS, 230Vac full load, cold start); 60A (50% Ipeak,twidth=200uS, 230Vac, full load, cold start)
<b>Dim Interface</b>	1-10V Dimming	1-10Vdimming 20mA Max (Passive 1-10V port)
	Synchronous Control	N/A
	High Low-level	N/A
	PWM Control	N/A
	Interface terminal wiring	N/A
<b>Sensor Parameters</b>	Operating Frequency	5.8 GHz ±75 MHz, ISM Band.
	Transmitting power	0.5mW Max.

Shenzhen Merrytek Technology Co.,Ltd

Add: 2<sup>nd</sup> and 3<sup>rd</sup> floor, NO.3 Building, 380 Xiangshan Avenue, Luotian, Yanluo, Baoan, Shenzhen, 518127,China

Tel: +86 (0)755-2305 7253

Fax: +86 (0)755-2786 3012

Website: www.merrytek.com

	Hold time	5S/30S/1min/3min/20min/30min 5s/30s/1min/3min/5min/10min/20min/30min(remote control)
	Stand-by DIM Level	10%(1.4±0.3V)/20%(2.5±0.5V)/50%(5.±1V) (Only DIP Switch)
	Stand-by Period	0S/5S/5min/10min/30min/1h/+∞ 0s/10s/1min/3min/5min/10min/30min/+∞ (Remote control)
	Detection Area	100%/75%/50%/10% 100%/75%/50%/25% (Remote control)
	Daylight Sensor	5Lux/15Lux/30Lux/50Lux/100Lux/150Lux/Disable ( Ambient light diffusion) 5lux/15lux/30lux/50lux/100lux/150lux/Disable (Remote control)
	Light control on/off	N/A
	Detecting Radius	See detection pattern
	Mounting Height	12m Max
	Detecting Angle	150°
<b>Operating Environment</b>	Operating Temperature	-25°C...+60°C
	Storage Temperature	Temperature:-40°C...+80°C; Humidity:10%-95% (non-condensing)
<b>Certificate Standards</b>	Safety standards	EN61058-1, UL60703-1
	EMC standards	EN300440; EN301489-1; EN55015; EN61547; EN61000-3-2; EN61000-3-3; EN62479
	Environmental Requirement	Compliant to RoHS
	Certificate	CE, RED,UL,FCC
<b>Others</b>	Input/output terminal specifications	Push-type terminal block; wire diameter: 0.75-1.5mm <sup>2</sup>
	IP Rating	IP20
	Protection Class	Class II
	Installation	Built-in installation
	Dimension	93.5*45*28.5mm
	Package	Bubble bag + partition + outer box (K=A)
	Net Weight	61.2G
	Lifetime	50,000h @Ta 230V full load

**Note**

1. "N/A" means not available.
2. Detection area is effected on volume of motion object and motion speed. The detection area is tested by a 165cm height person and walking speed is 0.5m/s.

### 3. Function

#### 1) On/OFF Function (stand-by period be set to "0"s)

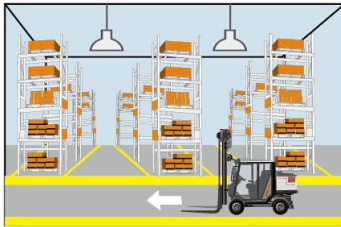

1 With sufficient ambient light, the light will not be switched on even if with motion signal.

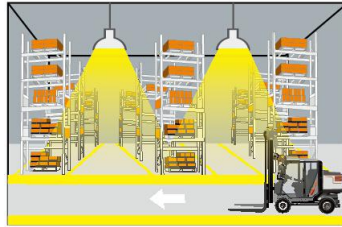

2 With insufficient ambient light, the sensor switches on the light when motion is detected.

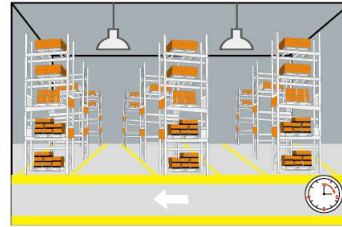

3 After elapse of hold time, the sensor switches off the light when no motion is detected.

#### 2) 2-step dimming function (stand-by period be set to "+∞")



1 If there is no motion detected, the light will be remained at a low light level all the time.

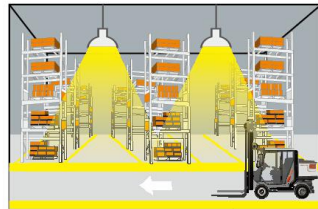

2 When motion is detected, the sensor will switch on the light to 100% brightness

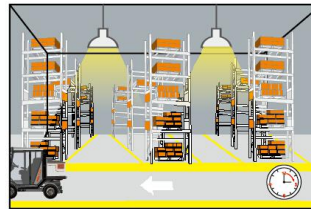

3 After elapse of hold time, the sensor dims the light at the present low light level if no motion is detected.

#### 3) 3-step dimming function (stand-by period be set to "10s/1min/3min/5min/10min/30min")

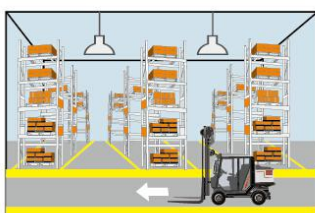

1 With sufficient ambient light, the light will not be switched on even if with motion signal.

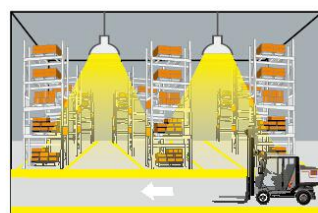

2 With insufficient ambient light, the sensor switches on the light when motion is detected.

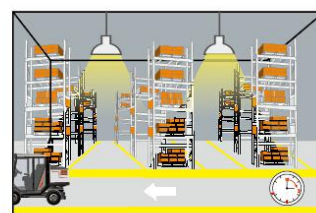

3 After elapse of hold time, the sensor dims the light at a low light level if no new motion is detected.

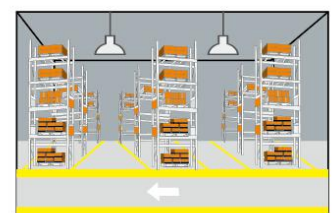

4 After elapse of standby period, the sensor switches off the light if no motion is detected in the detection zone.

### 4. Dimension (mm)

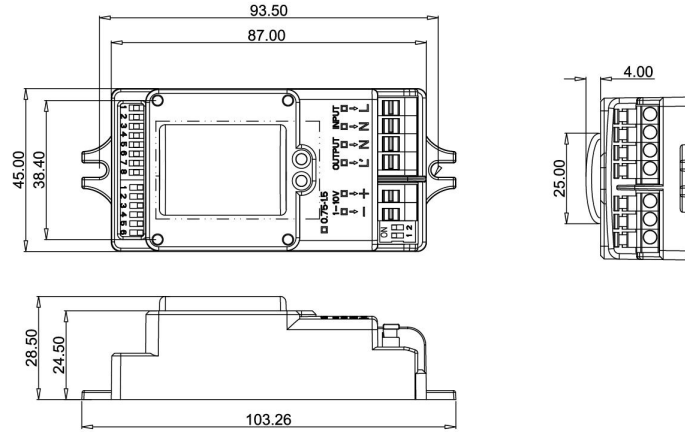

### 5. Wiring

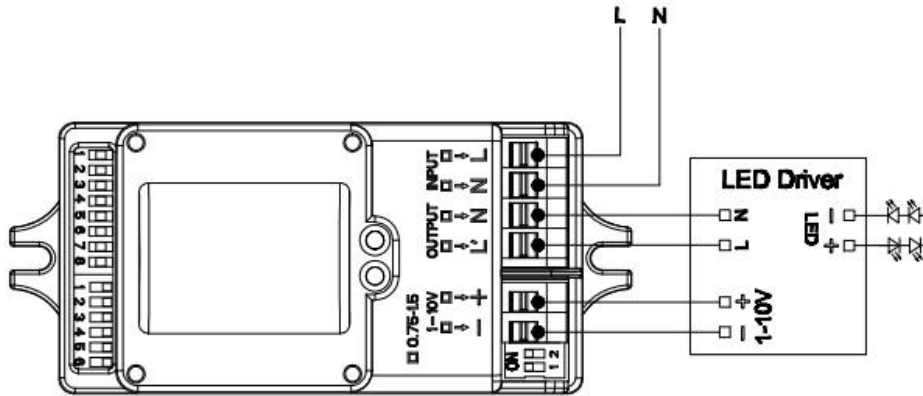

\*The sensor is designed for connect one load only. Connect more than one loads may damage the sensor.

### 6. Function Diagram

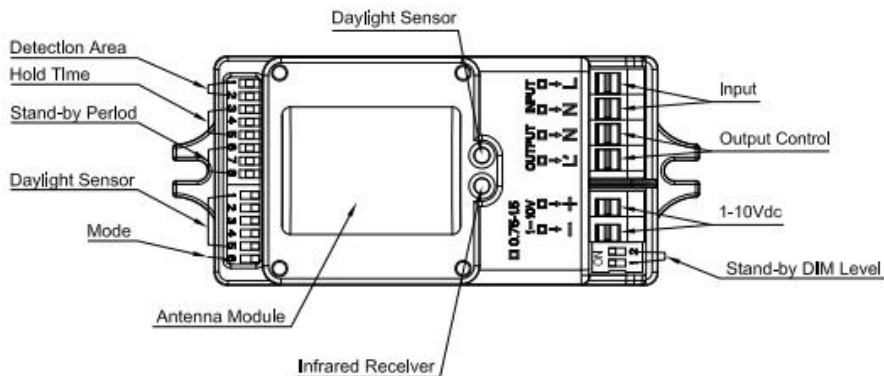

## 7. DIP Setting

### 1) Detection Area

	1	2	
I	ON	ON	100%
II	ON	-	75%
III	-	ON	50%
IV	-	-	10%

### 2) Hold Time

	3	4	5	
I	ON	ON	ON	5s
II	-	ON	ON	30s
III	ON	-	ON	1min
IV	-	-	ON	3min
V	ON	ON	-	20min
VI	-	-	-	30min

### 3) Stand-by Period

	6	7	8	
I	ON	ON	ON	0s
II	-	ON	ON	5s
III	ON	-	ON	5min
IV	-	-	ON	10min
V	ON	ON	-	30min
VI	-	ON	-	60min
VII	-	-	-	+∞

Shenzhen Merrytek Technology Co.,Ltd

Add: 2<sup>nd</sup> and 3<sup>rd</sup> floor, NO.3 Building, 380 Xiangshan Avenue, Luotian, Yanluo, Baoan, Shenzhen, 518127, China  
 Tel: +86 (0)755-2305 7253 Fax: +86 (0)755-2786 3012 Website: www.merrytek.com

4) Daylight Sensor

	1	2	3	4	5	
I	ON	ON	ON	ON	ON	5lux
II	-	ON	ON	ON	ON	15lux
III	ON	-	ON	ON	ON	30lux
IV	ON	ON	-	ON	ON	50lux
V	ON	ON	ON	-	ON	100lux
VI	ON	ON	ON	ON	-	150lux
VII	-	-	-	-	-	Disable*

5) Detection mode

	6	
I	ON	HS
II	-	LS

6) Stand-by dim Level

	1	2	
I	-	ON	50%
II	ON	-	20%
III	-	-	10%



## 8. Radiation Pattern

### Ceiling mounting

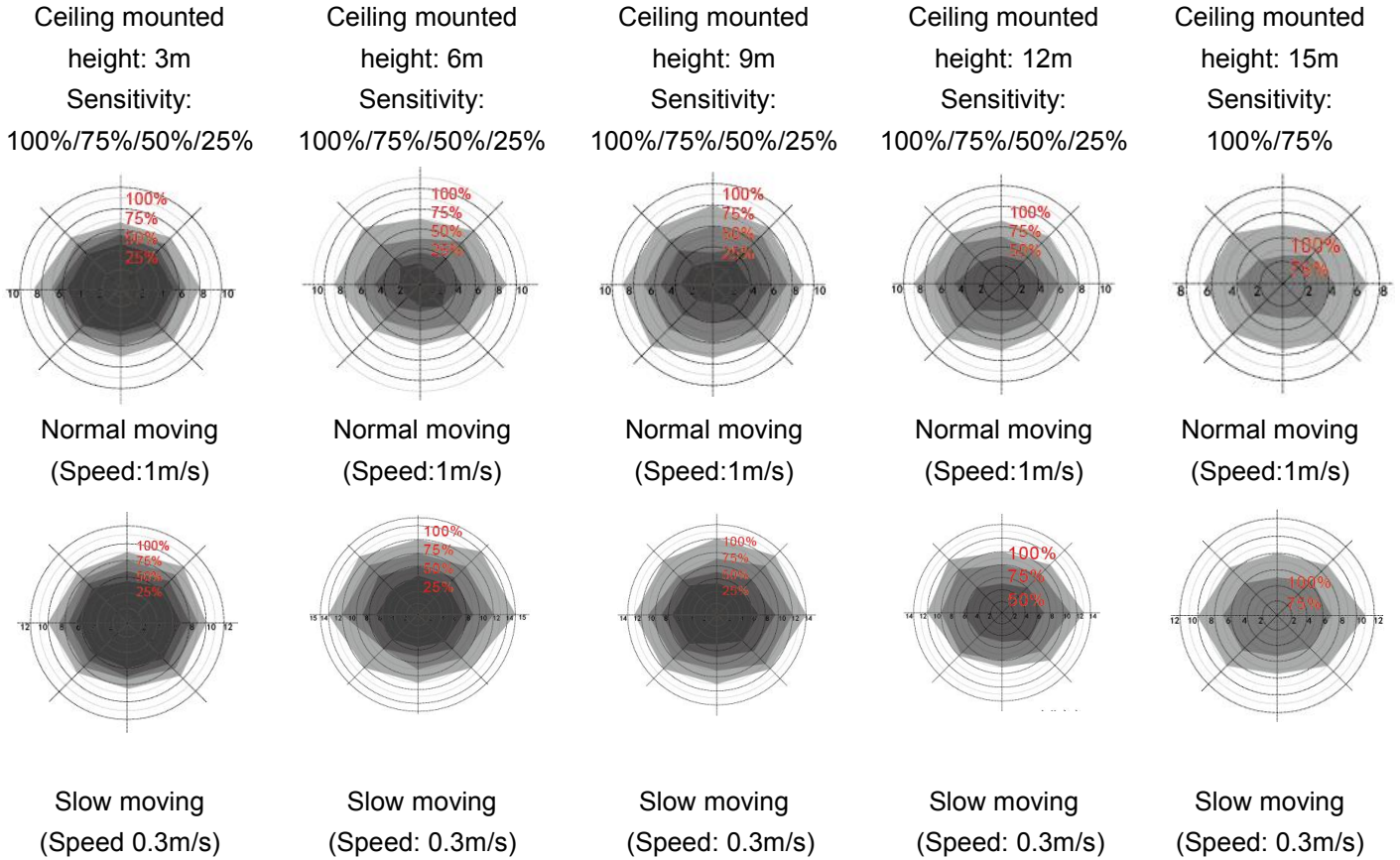

\*Only 100%/75%/50% detection sensitivity is workable when installed at 10m & 15m mounting height. 25% sensitivity is not able to detect motion signal.

### Wall mounting

Horizon mounted height: 2m  
Sensitivity: 100%/75%/50%/25%

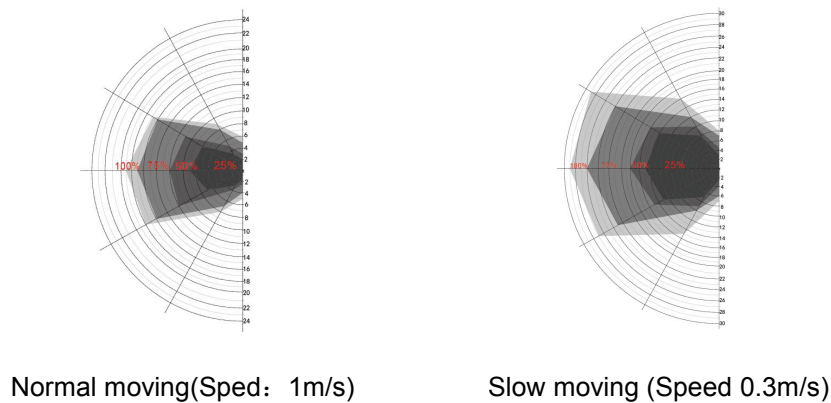



## 9. Remote Control

Remote Control Setting	Button	Remarks																								
		Press the "ON/OFF" button, the light goes to constant on/off mode, sensor is disabled. Press "Reset" "Auto mode" button to quit from this mode and the sensor starts to work.																								
		Press "Reset" button, all parameters are same as setting of DIP switch.																								
		Press "Sensor motion" button, the light quits from the constant on/ off mode, and the sensor starts to work ( The latest setting stays in validity )																								
		N/A																								
		N/A																								
		<table border="1"> <thead> <tr> <th>Scene Options</th> <th>Detection Area</th> <th>Hold Time</th> <th>Stand-by period</th> <th>Daylight Sensor</th> <th>Induction model</th> </tr> </thead> <tbody> <tr> <td>QS1</td> <td>100%</td> <td>5min</td> <td>10min</td> <td>30Lux</td> <td>HS</td> </tr> <tr> <td>QS2</td> <td>100%</td> <td>10min</td> <td>30min</td> <td>Disable</td> <td>HS</td> </tr> <tr> <td>QS3</td> <td>100%</td> <td>20min</td> <td>30min</td> <td>Disable</td> <td>HS</td> </tr> </tbody> </table> <p>Note: Detection area / Hold time / Stand-by period /Daylight sensor can be adjusted by pressing the corresponding button. The latest setting will stay valid.</p>	Scene Options	Detection Area	Hold Time	Stand-by period	Daylight Sensor	Induction model	QS1	100%	5min	10min	30Lux	HS	QS2	100%	10min	30min	Disable	HS	QS3	100%	20min	30min	Disable	HS
	Scene Options	Detection Area	Hold Time	Stand-by period	Daylight Sensor	Induction model																				
	QS1	100%	5min	10min	30Lux	HS																				
	QS2	100%	10min	30min	Disable	HS																				
	QS3	100%	20min	30min	Disable	HS																				
		Press the "TEST 2S" button can enter the test mode any time. At the mode, the sensor parameters as below: Detection Area is 100%, Hold Time is 5s, Stand-by Dim Level is 10%, Stand-by Period is 0s, daylight sensor disable. This function only for testing. Quit the mode by pressing "RESET" or any other function buttons.																								
		Press "HS" button to set the detection area to be high sensitive. Press "LS" button to set the detection area to be low sensitive. The adjustment bases on the "Detection Area" parameter you set.																								
		Daylight Sensor Set up daylight threshold: 5Lux/15Lux/30Lux/50Lux/100Lux/150Lux/ Disable.																								
		Stand-by period Set up stand-by time: 0S/10S/1min/3min/5min/10min/30min/+∞																								
		Hold time Set up hold time: 5S/30S/1min/3min/5min/10min/20min/30min																								
	N/A																									
	Detection Area Set up detection area: 25%/50%/75%/100%																									
	Remote Distance Toggle botton can set the remote distance of remote control and sensor.																									

## 10. Initialization

1/ On/Off function /3-step dimming function:

After power on, the sensor automatically turns on light at 100% brightness. After 10sec, it turns off the light. During the initialization, the sensor is not able to detect movement.

2/ 2-step dimming function:

After power on, the sensor automatically turns on light at 100% brightness. After 10sec, it dims the light to a low light level (set by stand-by dim level). During the initialization, the sensor is not able to detect movement.

## 11. Factory Setting

Detection area: 100%, Hold Time: 5S, Stand-by Period: 0S, Stand-by dim level:10%, Daylight Sensor: Disable

## 12. Application Notice

- 1). The product dimming function needs to be equipped with an 1-10V dimming LED driver.
- 2). The sensor should be installed by a professional electrician. Please turn off the power before installing, wiring, changing the setting of the DIP switch.
- 3). The sensor mounted in a plastic, glass lampshade would reduce the sensitivity of the sensor. For every 3 mm increase in thickness, the sensitivity would reduce by 20%.
- 4). The sensing distance will be affected by the height of the sensor installation, the size of the object being detected, and the speed of movement.
- 5). Daylight the value is in a sunny environment with no shadows and ambient light diffuse reflection conditions. The values illumination detected by sensor may vary in different environment, at different times, in different seasons, and in different climates.
- 6). The parameters of the sensor may need to be reconfigured in different installation environments. Please refer to the following instructions or contact the manufacturer.
- 7). This sensor is for indoor use only. Outdoor use will affect the waterproof effect, wind and moving objects around would cause false triggering.
- 8). The distance between any inductive sensors should be greater than 3m.
- 9). When the sensor is installed in a metal illuminance, a metal reflective surface, or a narrow enclosed environment, the microwave will be reflected repeatedly and cause false triggering. Please reduce the sensitivity or contact the manufacturer for technical support.
- 10). Do not place the sensor close to high-density objects such as metal, glass, mixed-use walls, etc. The sensor may be triggered by mistake.
- 11). Please ensure that there are no moving signals around the sensor, such as fan, DC motor, sewer, air outlet, etc., the sensor may generate false triggers.