

4309-1, 4310-1, 4311-1, 4312-1

120-277V Universal Voltage

Catalog #:		Type
Project:		Date
Prepared by:		

2' and 4' LED Strip Lights

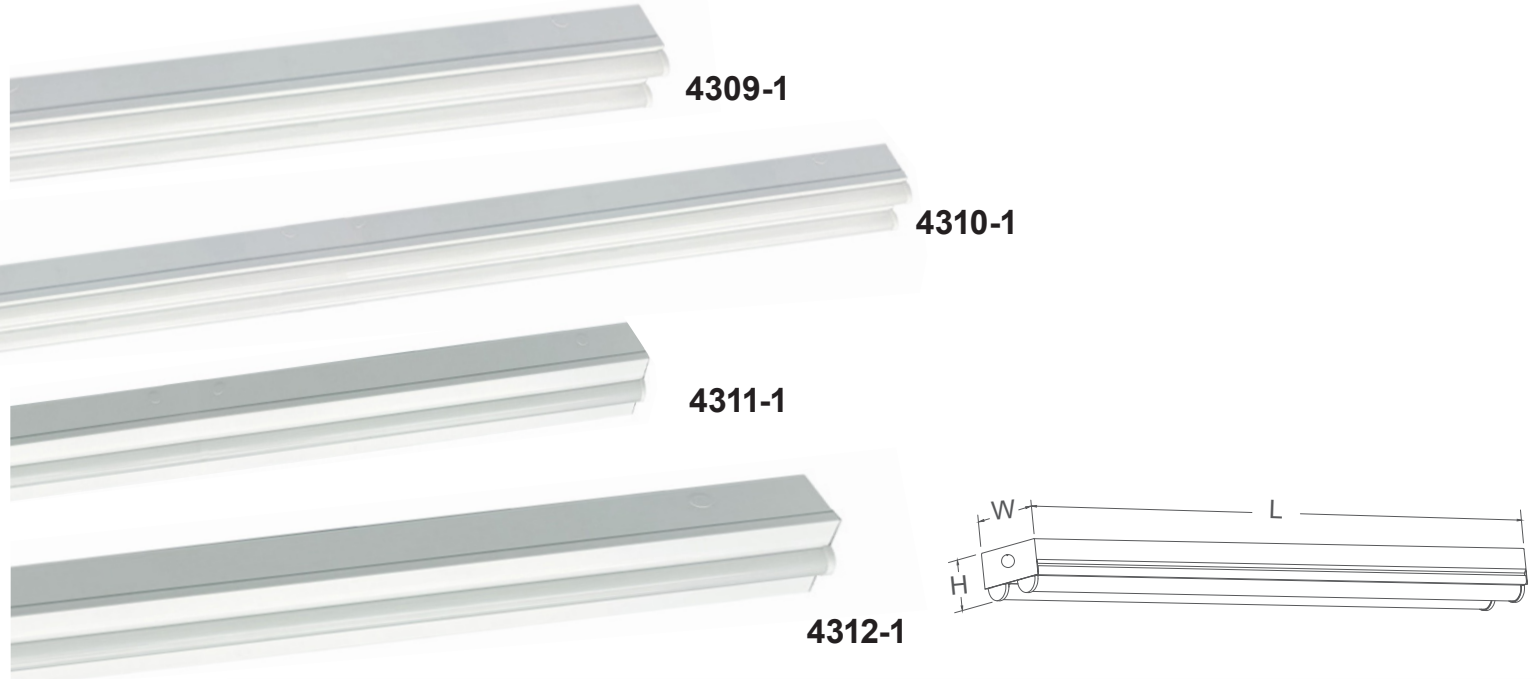

2' and 4' LED Strip Lights

DESCRIPTION

These LED Strip Lights provide general illumination in residential and light commercial applications. Easy maintenance with below ceiling access to the driver and surface or pendant mounting make these strip lights an easy choice for your project.

DESIGN FEATURES

Construction

- White Steel frame with polycarbonate lens
- End-to-end through wiring capable

Electrical

- 120-277V Universal Voltage
- 0-10V Dimming
- 50,000 hours projected life
- 4000K | 80 CRI
- 4309-1: 2' | 20W | 2100 lms
- 4310-1: 4' | 35W | 3675 lms
- 4311-1: 2' | 10W | 1050 lms
- 4312-1: 4' | 20W | 2100 lms

Mounting

- Suitable for surface or pendant mounting

Dimensions

- 4309-1: 24" x 3-1/4" x 2-3/4"
- 4310-1: 48" x 3-1/4" x 2-3/4"
- 4311-1: 24" x 3-1/4" x 2-3/4"
- 4312-1: 48" x 3-1/4" x 2-3/4"

Certifications

- CSAus listed for damp locations
- LED Lamp: 5 Year Limited Warranty
- Other Components: 1 Year Limited Warranty
- *Suitable for use in closets when installed in accordance to NEC Section 410.16 (C)(1)

ORDERING GUIDE

Example: 4310WH-1-EM

Model #	Emergency
4309WH-1 4310WH-1 4311WH-1 4312WH-1	(blank) no EM option -EM : EM adds Battery Backup*

* -EM option only available on 4310WH-1 and 4312WH-1

TEL: 800.937.6925 | Fax: 800.207.9509 | www.rplighting.com

Specifications and dimensions subject to change without notice.

11/14/24 R3



RP LIGHTING • FANS