

4313-2-30, 4314-2-30

4318-2-30

120V-60Hz

Catalog #:		Type
Project:		Date
Prepared by:		

LED Ceiling Mount Fixture

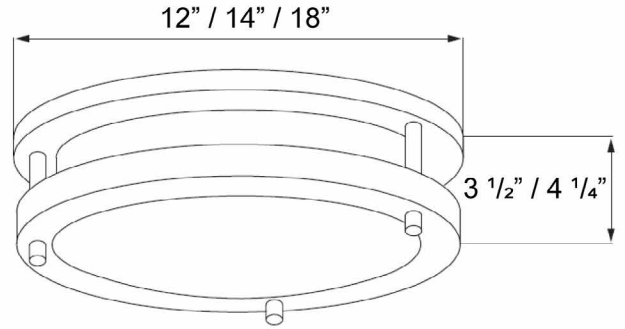

DESCRIPTION

This LED Surface Mount Fixture is an energy efficient LED light that comes complete with an integrated LED light engine. This fixture is mounted on a ceiling to provide light anywhere you need it.

DESIGN FEATURES

Construction

- Hard gauge metal back plate and heat sink to facilitate heat dissipation
- Acrylic Lens for even light distribution
- Plated Brush Nickel Finish

Electrical

- Available in 120V | 277V available on special order
- Dimmable TRIAC or ELV, 10-100%
- 50,000 hour projected life
- 3000K | 80 CRI
- 4313-2-30: 16W, 1394 lms (source), 1049 lms (delivered)
- 4314-2-30: 24W, 2095 lms (source), 1512 lms (delivered)
- 4318-2-30: 34W, 2454 lms (source), 2000 lms (delivered)

Lens

Lens replacement: 4313L-1, 4314L-1, 4318L-1

Dimensions

- 4313-2-30: 12" W x 3-1/2" H
- 4314-2-30: 14" W x 4-1/4" H
- 4318-2-30: 18" W x 4-1/4" H

Certifications

- cCSAus listed for damp location
- Energy Star Certified
- LED Light Source: 5 year limited warranty
- Other Components: 1 year limited warranty

ORDERING GUIDE

Example: 4313-2-30-BN-EM

Model #	Finish	EM Option ¹
4313-2-30	-BN : Brushed Nickel	blank : no EM option
4314-2-30		-EM : Adds battery pack*
4318-2-30		

* Only available on 4313-2 and 4314-2

TEL: 800.937.6925 | Fax: 800.207.9509 | www.rplighting.com

Specifications and dimensions subject to change without notice.



LED Light Source

Other Components

3/7/24 R1



RP LIGHTING · FANS

4313-2, 4314-2, 4318-2 - Ceiling Mount Fixture