

# 4615 Series

120V

Catalog #:		Type
Project:		Date
Prepared by:		

## E26 A19 No Lamp Mini Pendant

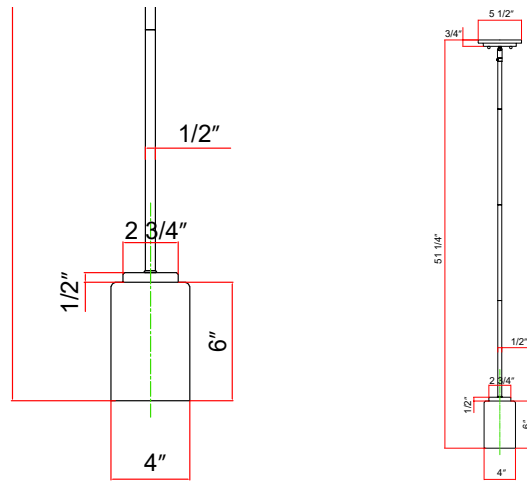

### DESCRIPTION

Maximize the light in your kitchen, dining area, or entry by adding an elegant touch with this sleek design and contemporary style mini pendant. Use LED lamps for energy efficiency.

### DESIGN FEATURES

#### Construction

- Heavy duty steel construction
- Frosted Opal Glass Shades

#### Electrical

- 120V-60Hz
- 9W E26 A19 LED Lamp (Not included)

#### Installation

- Ceiling Mount
- Ceiling Canopy fits standard electrical box

#### Certifications

- CSA-us Certified
- 1 Year Limited Warranty

### ORDERING

Example: 4615BN

Model	Finish
4615	
4615	<b>BN</b> : Brushed Nickel <b>MBK</b> : Matte Black

E26 A19 No Lamp Island Pendant

