

LED SURFACE DISK LIGHT INSTALLATION INSTRUCTIONS

IMPORTANT :

1. For your safety read and understand instructions completely before starting installation.
2. These luminaires (fixtures) are designed to meet the latest NEC requirements and are listed in full compliance with UL 1598.
3. Before attempting installation, check your local electrical code, as it sets the wiring standards for your locality.

⚠ WARNING - Risk of fire or electric shock.

1. Installation of this retrofit assembly requires a person familiar with the construction and operation of the luminaire's electrical system and the hazard involved. If not qualified, do not attempt installation. Contact qualified electrician.
2. Install this kit only in luminaires that have the construction features and dimensions described in these instructions, and where the input rating of the retrofit kit does not exceed the input rating of the luminaire.
3. LED Retrofit Kit installation requires knowledge of luminaires electrical systems. If not qualified, do not attempt installation. Contact a qualified electrician.

- WARNING - To prevent wiring damage or abrasion, do not expose wiring to edges of sheet metal or other sharp objects.
- Do not make or alter any open holes in an enclosure of wiring or electrical components during kit installation.
- This device is not intend for use with emergency exits or not for emergency lighting.

THE RETROFIT KIT IS ACCEPTED AS A COMPONENT OF A LUMINAIRE WHERE THE SUITABILITY OF THE COMBINATION SHALL BE DETERMINED BY CSA OR AUTHORITIES HAVING JURISDICTION.

INSTALLATION ONTO OUTLET BOX

1. Attach mounting plate to the outlet box by fastening supplied 1½" outlet box screws through mounting plate keyholes.(Fig.1)

FIG. 1

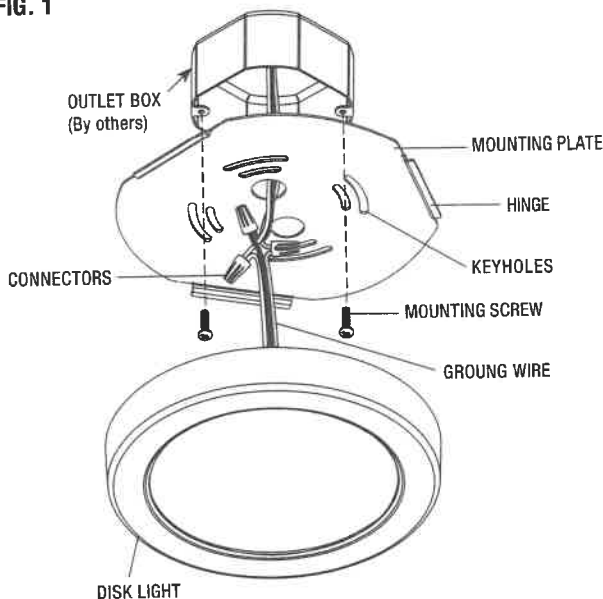

2. Align spring clips on the disk light to hinge on the mounting plate. Tuck all wires into the outlet box and push up to lock fixture in place (Fig. 2)

FIG. 2

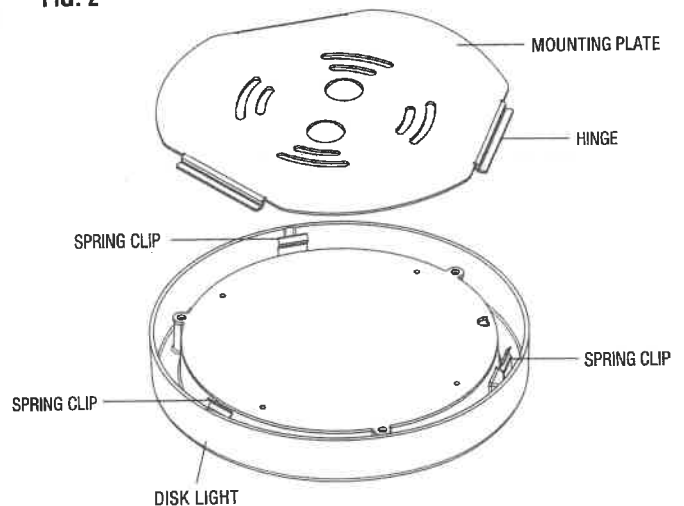

3. Make sure the disk Light is flush to the ceiling. (Fig. 3)

FIG. 3

Seal luminaire to surface around this entire edge.

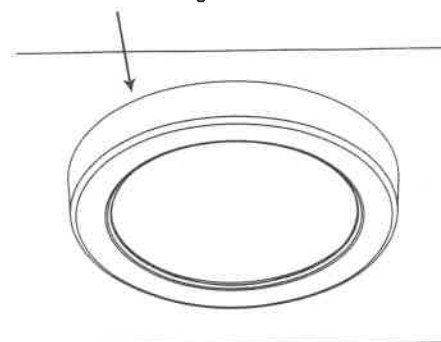

ELECTRICAL CONNECTION

1. Provide electrical service according to the "National Electrical Code" or your local electrical code to the outlet box.
2. Connect supply wires to fixture wires and insulate with proper size wire nuts (Fig. 1).
 - a.) Connect incoming ground wire (green or bare) to fixture ground wire (green or bare).
 - b.) Connect incoming common (white) wire to fixture common (white).
 - c.) Connect incoming hot (typically black) wire to fixture black wire.

NOTE : For wet locations, Fill the gap between the luminaire and the ceiling with waterproof glue after installation completed (Fig. 3).